



CAMPBELL IRONWORKS

curtain hardware

www.campbellironworks.com

campiron@hvc.rr.com

845.887.6420



HARRISON HARDWARE



1¼" Harrison Grande with Bauhaus Finial

The **Harrison Hardware** line offers our tradition of expert craftsmanship combined with innovative design. Hand forged heavy walled tubular poles [.120"] with solid finials and brackets comprise this elegant hardware line. All rods are welded to your desired length. Brackets and finials screw together, keeping rods in place.

HARRISON HARDWARE - WALL OR CEILING MOUNTED

<i>Item #</i>	<i>Description</i>
53700	¾" Harrison Petite Bracket End
53701	¾" Harrison Petite Bracket Center
54791	1¼" Harrison Grande Bracket End
54799	1¼" Harrison Grande Bracket Center
54739	Harrison Grande Double Bracket End - ¾" Back, 1¼" Front
54749	Harrison Grande Double Bracket Center - ¾" Back, 1¼" Front
03355	¾" By-Pass Bracket
03455	1¼" By-Pass Bracket

Prices include Bauhaus Finial

IRON RODS, ROD CONNECTORS + ROD HINGES

01355	¾" Hammer Finished Rod/per Foot
01455	1¼" Hammer Finished Rod/per Foot
02345	¾" Rod Connector
02346	¾" Rod Hinge
02445	1¼" Rod Connector
02446	1¼" Rod Hinge

HARRISON HARDWARE



3/4" Harrison Petite Bracket with Bauhaus Finial



1 1/4" Harrison Grande Bracket with Bauhaus Finial



3/4" Harrison Petite Center Bracket



Harrison Grande Double End Bracket



3/4" Harrison Petite Bracket with Short Bauhaus Finial



Harrison Grande Double Center Bracket



By-Pass Bracket with C Rings



Harrison Double Curtain Rod

COCO HARDWARE



¾ Coco Bracket with Bauhaus Finial

A handsome blend of contemporary and traditional styling allows **Coco Hardware** to be used in modern to timber frame decor. High quality forged steel brackets with heavy walled tubular poles [.120"] characterize the **Coco** line. Brackets and finials link together, keeping rods in place without set screws or other fasteners. All rods are made to your specified length.

COCO HARDWARE

<i>Item #</i>	<i>Description</i>
23301	¾" Coco Single Bracket End
23301	¾" Coco Single Bracket Center
23470	1¼" Coco Single Bracket End
23471	1¼" Coco Single Bracket Center
23634	Coco Double Bracket End
23333	Coco Double Bracket Center [2 x ¾" Rods]
23636	Coco Double Bracket Center [1 x ¾" & 1 x 1¼" Rods]
23644	Coco Double End Bracket [2 x 1¼" Rods]
23444	Coco Double Center Bracket [2 x 1¼" Rods]
03355	¾" By-Pass Bracket
03455	1¼" By-Pass Bracket

IRON RODS, ROD CONNECTORS + ROD HINGES

<i>Item #</i>	<i>Description</i>
01355	¾" Hammer Finished Rod/per Foot
01455	1¼" Hammer finished Rod/per Foot
02345	¾" Rod Connector
02346	¾" Rod Hinge
02445	1¼" Rod Connector
02446	1¼" Rod Hinge

COCO HARDWARE FINIALS

00351	¾" Flair Finial
00352	¾" Bauhaus Finial
00354	¾" Javelin Finial
00353	¾" Ball Finial
00451	1¼" Flair Finial
00452	1¼" Bauhaus Finial
00454	1¼" Javelin Finial
00453	1¼" Ball Finial

COCO HARDWARE



3/4" Coco Bracket with Flair Finial



1 1/4" Coco Bracket with Bauhaus Finial



3/4" Coco Bracket with Ball Finial



Coco Double Bracket with Ball Finial & Short Bauhaus Finial



3/4" Coco Bracket with Javelin Finial



Coco Double Bracket with Flair Finial & Short Bauhaus Finial



By-Pass Bracket 3/4" #03355, 1 1/4" #03455



Coco Double Curtain Rod

MIRA HARDWARE



1¼" Mira End Bracket with Bauhaus Finial and Chase Detail

The **Mira Hardware** features a high quality Nickel finish which makes it a perfect hardware for interiors, outdoors or bathrooms. The **Mira** rods are heavy walled tubular poles [1/8"]. Rods and finials are made of stainless steel. Brackets are fabricated from solid aluminum with a nickel finish in order to achieve a sturdy but light weight effect. Brackets and finials link together, keeping rods in place without set screws or other fasteners. All rods made to your specified length.

Hinges for bay windows and corners available.

¾", 1¼" Single and Double Curtain Rod styles.

MIRA HARDWARE

Item #	Description
25300	¾" Single Wall Bracket End
25301	¾" Single Wall Bracket Center
25470	1¼" Single Wall Bracket End
25471	1¼" Single Wall Bracket Center
25634	Double Wall Bracket End
25636	Double Wall Bracket Center
25302	¾" Socket Bracket
25402	1¼" Socket Bracket

ROD, ROD CONNECTORS + ROD HINGES

25300	¾" Single Wall Bracket End
25301	¾" Single Wall Bracket Center
25470	1¼" Single Wall Bracket End
25471	1¼" Single Wall Bracket Center
25634	Double Wall Bracket End
25636	Double Wall Bracket Center
25302	¾" Socket Bracket
25402	1¼" Socket Bracket

MIRA FINIALS

25362	¾" Bauhaus Finial
25363	¾" Bauhaus Finial w/Chase Detail
25462	1¼" Bauhaus Finial
25463	1¼" Bauhaus Finial w/Chase Detail

MIRA HARDWARE

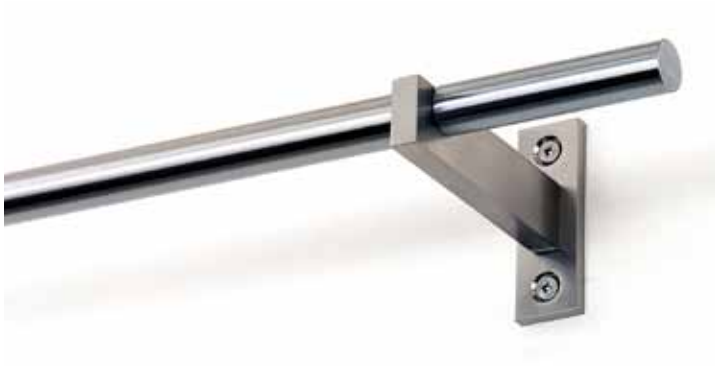

3/4" Mira End Bracket with Bauhaus Finial



1 1/4" Mira End Bracket with Bauhaus Finial and Chase Detail



Mira Center Bracket



1 1/4" Mira End Bracket with Short Bauhaus Finial and Chase Detail



3/4" Mira End Bracket with Short Bauhaus Finial



Mira Double End Bracket



3/4" Mira End Bracket with Bauhaus Finial with Nickel Finish Rings



Mira Double End Bracket

LINCOLN HARDWARE



½" Lincoln End Bracket and Finial



½" Lincoln End Bracket and Short Finial



¾" Center Lincoln Bracket



¾" Lincoln End Bracket and Finial

Minimal meets traditional in the **Lincoln Hardware** line. The links are flattened to keep the rods and brackets on the same plane. All rods are welded to your specified length. Available in Wrought Iron Gray, Bronze or German Silver Finish.

LINCOLN HARDWARE - BRACKETS + FINIALS

Item #	Description
72896	½" Tommy Bracket and Finial End
72700	½" Tommy Bracket Center
73896	¾" Tommy Bracket and Finial End
73700	¾" Tommy Bracket Center

IRON RODS, ROD CONNECTORS + ROD HINGES

01255	½" Hammer Finished Rod/per Foot
01355	¾" Hammer Finished Rod/per Foot
02245	½" Rod Connector
02246	½" Rod Hinge
02345	¾" Rod Connector
02346	¾" Rod Hinge

OLIVIA HARDWARE



Olivia Center Bracket with Rod Hinge



Olivia End Bracket with Flair Finial



Olivia End Bracket with Ball Finial

Our **Olivia Hardware** is the most traditional style featuring hand forged solid steel brackets and finials. 1/2" rods are solid, 3/4" and 1 1/4" rods are tubular. Available in Wrought Iron Gray, Bronze or German Silver Finish.

OLIVIA HARDWARE

Item #	Description
62700	1/2" Olivia Bracket End
62701	1/2" Olivia Bracket Center
63700	3/4" Olivia Bracket End
63701	3/4" Olivia Bracket Center
64700	1 1/4" Olivia Bracket End
64701	1 1/4" Olivia Bracket Center

OLIVIA HARDWARE FINIALS

00251	1/2" Flair Finial
00252	1/2" Bauhaus Finial
00253	1/2" Ball Finial
00351	3/4" Flair Finial
00352	3/4" Bauhaus Finial
00354	3/4" Javelin Finial
00353	3/4" Ball Finial
00451	1 1/4" Flair Finial
00452	1 1/4" Bauhaus Finial
00454	1 1/4" Javelin Finial
00453	1 1/4" Ball Finial

TOMMY HARDWARE



Tommy End Bracket with Flair Finial



Tommy Center Bracket

Authenticity meets function in our **Tommy Hardware** line. A hammered nail head finial with matching hammered bracket ends. A flattened link keeps rods and brackets on the same plane. Excellent when you want hardware close to the ceiling or non-intrusive. All rods are welded to your size. Available in 1/2" diameter only.

TOMMY HARDWARE

Item #	Description
72896	1/2" Tommy End Bracket and Flair Finial
72700	1/2" Tommy Center Bracket

CRANE CURTAIN RODS



1" Dia. Crane Curtain Rod with Disk Finial



1" Dia. Crane Curtain Rod Detail

Our **Crane Rods** are designed to operate smoothly, while upholding their reputation as the strongest in the industry. 1" Crane Rods are capable of holding long banners, quilts, tapestries as well as heavy curtains up to 6' wide without end support. 1/2" rods have 3 projections [3/4", 2" and 3"] in order to place the rod in the right position over moldings or when extended out from the wall. Ball finials are included with 1/2" rods only. Available in Wrought Iron Gray, Antique Bronze or German Silver Finish.



1/2" Dia. Crane Curtain Rod

1/2" CRANE CURTAIN RODS + BALL FINIALS

Item #	Description
32873	3/4" Projection Crane Rod up to 36" L
32874	3/4" Projection Crane Rod up to 48" L
32823	2" Projection Crane Rod up to 36" L
32824	2" Projection Crane Rod up to 48" L
32833	3" Projection Crane Rod up to 36" L
32834	3" Projection Crane Rod up to 48" L

Ball Finials included

1" CRANE CURTAIN ROD BRACKETS

32122	2" Projection x 1" Rod Crane Bracket
32123	3" Projection x 1" Rod Crane Bracket
32124	4" Projection x 1" Rod Crane Bracket

1" RODS AND FINIALS

01155	1" Hammer Finish Rod/per Foot
00150	1" Disc Finial
00153	Ball Finial for 1" Rod



1/2" Dia. Crane Rod 3/4" Projection



1/2" Dia. Crane Rod 3" Projection

RETURN CURTAIN RODS



1 1/4" Return Curtain Rod



3/4" Dia. Return Curtain Rod



3/4" Dia. Stainless Steel Return Curtain Rod



1 1/4" Return Curtain Rod End Detail



3/4" Dia. Stainless Steel Return Curtain Rod Detail

Our **Return Rods** are clean and elegant yet sturdy and functional. A minimal curtain rod with no finials, perfect for eliminating light or to conceal window frames. Available in 3/4" and 1 1/4" diameter iron rod, also in 3/4" diameter stainless steel rod.

RETURN CURTAIN RODS

Item #	Description
34301	3/4" Iron Return Rod
34401	1 1/4" Iron Return Rod
34321	3/4" Stainless Return Rod

Mounting brackets included

ROD LENGTH

01355	3/4" Iron Rod/per Foot
01455	1 1/4" Iron Rod/per Foot
25355	3/4" Stainless Steel Rod/per Foot

12 SOCKET BRACKETS + SHOWER RODS



Stainless Steel Socket Bracket and Rod Detail



Wrought Iron Socket Bracket and Rod Detail



Stainless Steel Socket Bracket and Rod

Our **Socket Brackets** are engineered for wall to wall installation or to work with all our other hardware lines. Nickel hardware is solid stainless steel and will not rust outdoors or in bathrooms. May be used for shower curtains.



Wrought Iron Socket Bracket and Rod

SOCKET BRACKETS

Item #	Description
82006	¾" Wrought Iron Socket Bracket
82007	1¼" Wrought Iron Socket Bracket
25302	¾" Stainless Steel Bracket
25402	1¼" Stainless Steel Socket Bracket

CAFÉ + DOOR CURTAIN RODS



Café and **Door Curtain Rods** are designed to be delicate and versatile enough to mount on doors or window frames. Two rods may be used on top and bottom to stretch fabric across windows or French doors for privacy. Longer rods can be achieved by adding brackets and overlapping the flat sections of the rods. 3/8" smooth rod only.



CAFÉ CURTAIN RODS

Item #	Description
33001	2 Café Rod Brackets with Rod up to 36" L
33002	2 Café Rod Brackets with Rod up to 48" L

*Café Rod projections available: 1", 1½", 2"
Longer lengths available, call for details.*

new

CASA COLLECTION



3/4" Casa Bracket and Short Disc Finial w/ Antique Bronze Finish



1 1/4" Casa Bracket and 2" Bauhaus Finial w/ Wrought Iron Gray Finish



1 1/4" Casa Bracket and 2" Brass Bauhaus Finial w/ Wrought Iron Gray Finish



3/4" Casa Bracket and Long Disc Finial w/ German Silver Finish



1 1/4" Casa Bracket and 1" Bauhaus Finial w/ Wrought Iron Gray Finish



1 1/4" Casa Bracket and Extended Brass Bauhaus Finial w/ Wrought Iron Gray Finish



1 1/4" Casa Bracket and Hex Finial w/ Wrought Iron Gray Finish



1 1/4" Casa Bracket and Lancea Finial w/ Wrought Iron Gray Finish



1 1/4" Casa Bracket and Brass Bullet Finial w/ Wrought Iron Gray Finish



Casa Double Curtain Rod



Casa Double Curtain Rod



Casa Double Curtain Rod

Our newest hardware line, the **Casa Collection** features smooth curtain rods in 3/4" and 1 1/4" diameters with minimal brackets. Available with some exciting new finials in brass and iron.

CASA BRACKETS

Item #	Description
24300	3/4" Casa End Bracket
24300	3/4" Casa Center Bracket
24400	1 1/4" Casa End Bracket
24401	1 1/4" Casa Center Bracket
24634	Casa Double End Bracket
24636	Casa Double Center Bracket

CASA RODS, CONNECTORS + HINGES

01356	3/4" Casa Smooth Rod
01456	1 1/4" Casa Smooth Rod
01345	3/4" Casa Rod Connector
01346	3/4" Casa Rod Hinge
01445	1 1/4" Casa Rod Connector
01446	1 1/4" Casa Rod Hinge

CASA FINIALS

00335	3/4" Casa Disc Finial
00336	3/4" Casa Disc Finial Extended
00361	3/4" Casa Bauhaus Finial 1" L
00362	3/4" Casa Bauhaus Finial 2" L
00363	3/4" Casa Bauhaus Finial 3 1/2" L
00364	3/4" Casa Brass Bauhaus Finial 1" L
00365	3/4" Casa Brass Bauhaus Finial 2" L

CASA FINIALS [Continued]

00366	3/4" Casa Brass Bauhaus Finial 3 1/2" L
00367	3/4" Casa Brass Bauhaus Finial Ext. 4" L
00368	3/4" Casa Brass Bullet Finial
00369	3/4" Casa Hex Finial
00435	1 1/4" Casa Disc Finial
00436	1 1/4" Casa Disc Finial Extended
00461	1 1/4" Casa Bauhaus Finial 1" L
00462	1 1/4" Casa Bauhaus Finial 2" L
00463	1 1/4" Casa Bauhaus Finial 3 1/2" L
00464	1 1/4" Casa Brass Bauhaus Finial 1" L
00465	1 1/4" Casa Brass Bauhaus Finial 2" L
00466	1 1/4" Casa Brass Bauhaus Finial 4" L
00467	1 1/4" Casa Brass Bauhaus Finial Ext. 4" L
00468	1 1/4" Casa Brass Bullet Finial
00469	1 1/4" Casa Hex Finial

CEILING HARDWARE



Coco Ceiling Bracket with Bauhaus Finial



Coco Ceiling Center Bracket



Coco Ceiling Bracket with Ball Finial



Coco Ceiling Bracket with Flair Finial



Harrison Petite Ceiling Bracket



Harrison Petite Ceiling Bracket With Short Finial



Olivia Ceiling End Bracket with Flair Finial



Olivia Ceiling Center Bracket with Rod Hinge

Our company has the most **Ceiling Curtain Rod** styles. We have standard drop sizes and the ability to make custom drops when you need to clear soffits or other architectural details. Create a vestibule around drafty doors or a simplified installation for bay windows. Dramatic around beds as well as for floor to ceiling drapes.

CEILING CURTAIN ROD BRACKETS

Item #	Description
53700	¾" Harrison Petite Bracket End
53701	¾" Harrison Petite Bracket Center
54791	1¼" Harrison Grande Bracket End
54799	1¼" Harrison Grande Bracket Center
13700	¾" Olivia Ceiling Bracket End
13701	¾" Olivia Ceiling Bracket Center
14700	1¼" Olivia Ceiling Bracket End
14701	1¼" Olivia Ceiling Bracket Center
23700	¾" Coco Ceiling Bracket End
23701	¾" Coco Ceiling Bracket Center
23740	1¼" Coco Ceiling Bracket End
23741	1¼" Coco Ceiling Bracket Center

CURTAIN RINGS + ACCESSORIES



Linked Stainless Steel Tieback



Stainless Steel Wrought Iron Tieback



Linked Wrought Iron Tieback



Nickel Finish Curtain Ring



Wrought Iron Rod Batons



Wrought Iron Curtain Rings



Wrought Iron Curtain Rings



Fixed Wrought Iron Tieback

ACCESSORIES

Item #	Description
95001	Linked Tieback
95002	Fixed Tieback
95003	1/2" Rod Baton
95004	3/4" Rod Baton
95005	1 1/4" Rod Baton
91102	Curtain Ring for 1/2" Rod
91103	Curtain Ring for 3/4" Rod
91104	Curtain Ring for 1 1/4" Rod
91103-C	Bypass Curtain Ring for 3/4" Rod
91104-C	Bypass Curtain Ring for 1 1/4" Rod
25001	Stainless Steel Linked Tieback
25004	3/4" Stainless Steel Rod Baton
25005	1 1/4" Stainless Steel Rod Baton
25103	3/4" Stainless Steel Curtain Ring
25104	3/4" Stainless Steel Curtain Ring



CAMPBELL IRONWORKS

22 n. horton avenue, callicoon, ny 12723

Presorted
Standard
US Postage
PAID
Oakland, CA
Permit #2319

CAMPBELL IRONWORKS specializes in the manufacturing of handcrafted curtain hardware. Our products are the result of many years of collaborating with designers and workrooms. We have created unique hardware systems which link or screw together to hold rods in place. This catalog represents years of listening to what our customers need. We use quality materials and spare no effort to insure top quality products. All hardware and rods are made to your desired size in Upstate New York. Our friendly expert staff is always available to help you choose the right hardware for your project.

HOW TO MEASURE

Our preferred measurement is Bracket Center to Bracket Center. Finial Lengths can be found on our website, most finials are available in custom lengths at no additional cost. Order Forms specifically designed for each of our hardware lines including **Bay Windows**, **Corners** and **Curves** may be downloaded from our website.

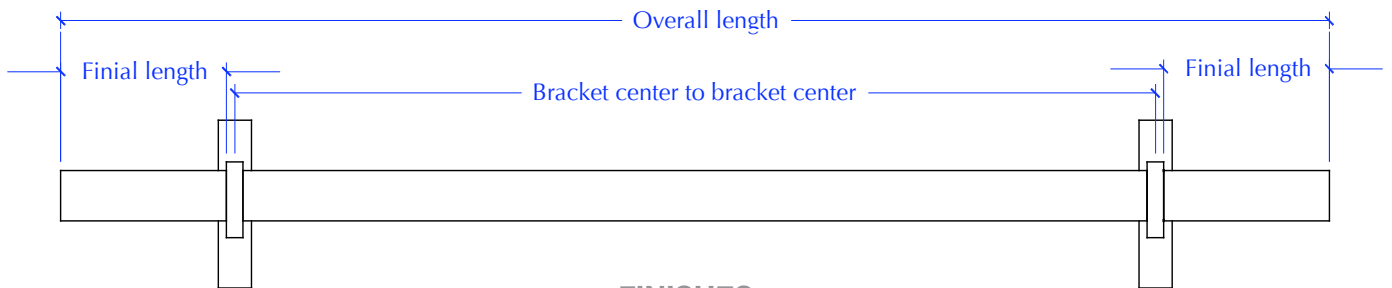

FINISHES



Bronze

Wrought Iron Gray

German Silver